

# WSG-09

## Gearless Synchronous Lift Machines

Code **PM.8.004799.EN**

Version -

Date **14.11.2018**



No part of this publication may be reproduced or translated, even in part, without prior written permission from WITTUR.

Subject to change without notice!

info.cn@wittur.com  
www.wittur.com

© Copyright WITTUR 2018



---

**Gearless Synchronous Lift Machines**  
**WSG-09**  
Operating and maintenance manual

---

Page	001
Date	14.11.2018
Version	-
Code	PM.8.004799.EN

These operating instructions are applicable to lift machines:

## **WSG - 09**

with block brake

WITTUR reserves the right to correct or change the contents of this manual and these product details without prior notice. We expressly reserve the right to make technical changes which improve the products or their safety standards without prior notice. No liability can be accepted for damage, injuries or expense arising therefrom. We cannot guarantee the correctness and completeness of the details.



Wittur Elevator Components (Suzhou) CO., Ltd.  
18 Shexing Road, FOHO Economic Development  
Zone Wujiang City, Jiangsu Province, P.R. China  
Tel: +86-512-82072888  
Fax: +86-512-63220044  
info.cn@wittur.com



## Index

1. General safety instructions.....	003
2. Product description.....	004
3. Nameplate.....	005
4. Technical data.....	006
5. Dimension drawing.....	007
6. Scope of supply.....	008
7. Transport and storage.....	008
8. Installation.....	009
9. Electrical connection.....	010
9.1 General.....	010
9.2 Motor connection / Winding protection.....	010
9.3 Speed/Position measuring feedback system.....	012
9.3.1 Measuring feedback system ERN 1313.....	012
9.3.2 Measuring feedback system ERN 1387.....	012
9.3.3 Measuring feedback system TS5213N2503.....	013
9.3.4 Measuring feedback system Weton EI53C9.25-2048-SA5N2T.....	013
9.4 Brake.....	013
10. Commissioning.....	014
11. Operation and maintenance.....	015
11.1 General.....	015
11.2 Maintenance intervals.....	015
11.3 Brake remote release for MRL solution.....	016
11.4 Mechanical evacuation device.....	016
11.5 Replacing the traction sheave.....	016
11.6 Brake.....	017
11.7 Removing encoder system.....	020
11.8 Trouble shooting.....	022
12. Accessories.....	023
12.1 Connecting cable for encoder systems.....	023
12.2 Hand wheel of mechanical evacuation device.....	024
12.3 Brake remote release.....	024
12.4 Manual brake release wrench.....	024
13. Spare parts.....	025

## 1. General safety instructions

### Explanation of symbols used in these instructions



Danger

means that death or serious injury to persons or serious damage to property will occur unless the appropriate precautions are taken.



Warning

means that death or serious injury to persons or serious damage to property may occur unless the appropriate precautions are taken.



Caution

means that injuries to persons or damage to property may occur unless the appropriate precautions are taken.



Note

points out important information and operating instructions. If these are not observed, damage, hazards or faults may result.

### Intended use

The WSG-09 lift machines have been manufactured in compliance with the latest state of the art and recognized safety regulations. They may only be used for their intended purpose or in combination with all safety devices according to the correct procedure. The WSG-09 may only be used for driving lifts. "Intended use" also requires that the instructions contained in the documentation supplied with the machine and the commissioning instructions be observed, and that the specified inspection and maintenance work be carried out.

### Warranty and liability

Our "Conditions of Sale and Delivery" shall apply for all our supplies and services. The warranty period is 24 months from the date of manufacture. We do not undertake any warranty or liability claims for personal injury or property damage resulting from one or more of the following causes:

- Improper use of the WSG-09 lift machine
- Improper installation, commissioning, operation or maintenance
- Operation of the WSG-09 with defective and/or inoperative safety or protective devices
- Non-compliance with the instructions contained in the operating instructions or other documentation supplied
- Unauthorized structural modifications to the WSG-09
- Insufficient monitoring of parts subject to wear
- Repairs carried out improperly
- Emergencies caused by external forces or force majeure

### Safety precautions

Only qualified personnel are authorized to perform any planning, installation or maintenance work, and this must be done in accordance with the relevant instructions.

The personnel must be trained for the job and must be familiar with the installation, assembly, commissioning and operation of the product.

The WSG-09 lift machine is intended for use in an enclosed, lockable machine room and is accessible only to qualified personnel and customer authorized personnel.



Danger

- The instructions given in this manual or any other instructions supplied must always be observed to avoid danger or damage.

- WSG-09 lift machines are not ready-to-use products; they may only be operated after they have been installed in lift systems and their safe operation has been ensured by taking the appropriate measures.

- Check the proper functioning of the motor and the brake after installing the machine.

- Repairs may only be carried out by the manufacturer or an authorized repair agency. Unauthorized startup and intervention may result in injuries to persons and property.

- The machines are not designed for direct connection to the three-phase power system but are to be operated via an electronic frequency converter. Direct connection to the mains may destroy the motor.



Warning

- The machines can only be installed vertically in machine rooms or at the top of the shafts.

- High surface temperatures may occur on the external parts of the machine. Therefore, no temperature-sensitive parts may be in contact with these parts or attached to them. Protection against accidental contact should be provided, if required.

- High voltages are applied at the terminal connections during the operation of synchronous motors.

## 2. Product description

The permanent-magnet gearless synchronous lift machines WSG-09 are structurally compact and can be used in the machine rooms or MRL. They are distinguished by their high efficiency, extremely low noise, slight vibration and excellent operating characteristics. They can only be installed vertically in machine rooms or at the top of shafts.

The WSG-09 gearless synchronous lift machines are designed solely for use with frequency converters. They can be supplied for several rated speeds, which can then be further adapted to meet the specific needs of users.

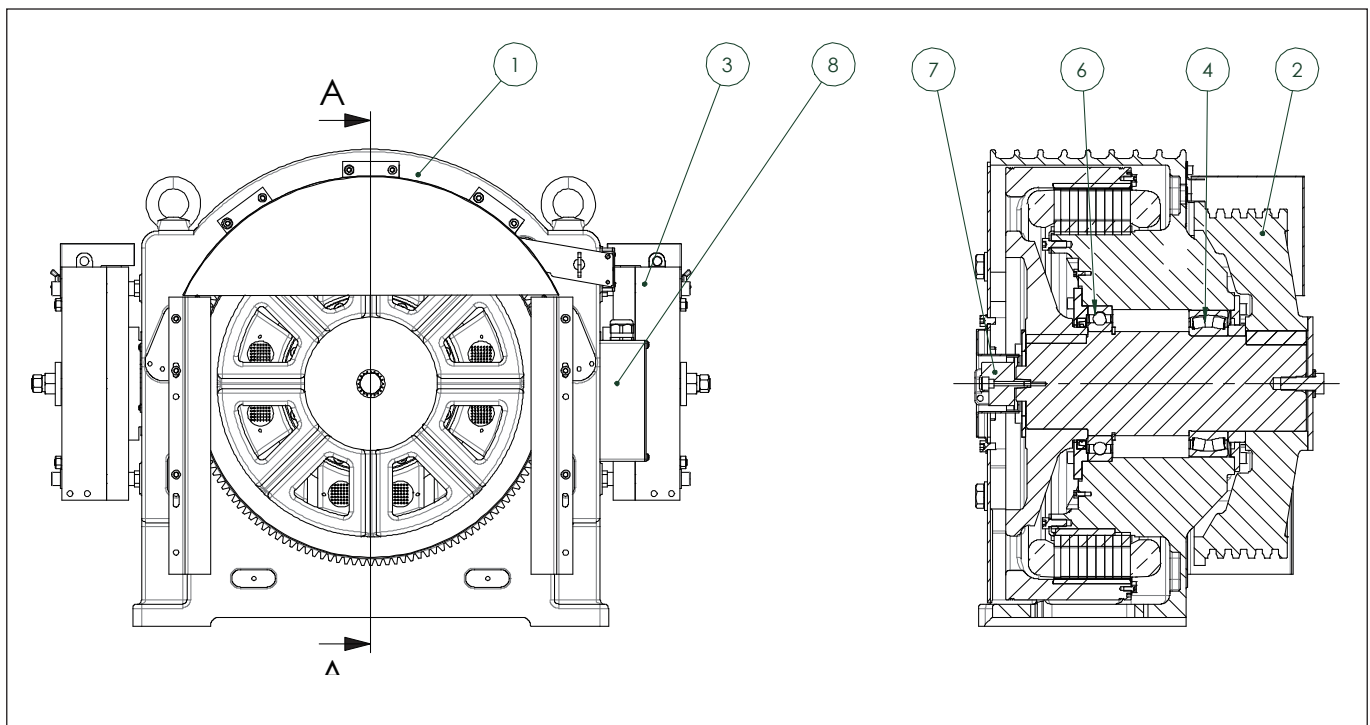

The machine is composed by a permanent-magnet motor (1), a traction sheave (2) and block brakes (3). The rope slip off guard is designed to avoid the rope jumping out of the traction sheave. The axle load of lift machine is up to 35KN. The rotor shaft is fixed to the base by a self-aligning roller bearing (4) at the traction sheave side. The front face of the motor has a hole for connecting and fixing the mechanical evacuation device. Both front and rear bearings are double sealed bearings.

A measuring feedback system (7) is located at the rear side of the lift machine. The brakes with their own terminal are powered on by 110V DC. The motor terminal and terminal for temperature monitoring device are installed inside the terminal box (8). The brakes are designed such that in the case of failure of one brake the remaining brake is able to brake the elevator at full load. They are also able to be released manually or a remote release device can be operated as needed.





### 3. Nameplate

The nameplate of the lift machine is on the motor and provides the basic information.

 PM Gearless Elevator Traction Machine 		
WSG-09		Serial Nr :
3 ~ Star		Rated Load: [kg]
Rated Voltage [ V ] 380	Rated Current [ A ]	Rated Speed [ min <sup>-1</sup> ]
Rated Frequency [ Hz ]	Rated Power [ kW ]	Rated Torque [ Nm ]
Insulation Class F	Duty Cycle S3-40%	ke [ V/min <sup>-1</sup> ]
Degree Of Protection IP40	Weight [ kg ]	Nr. Of Poles
Brake Type WB4600 B	JM [ kgm <sup>2</sup> ]	Manufacture Date
Ru [ Ω ]	Lu [ mH ]	Power factor [CosΦ]
Wittur Elevator Components (Suzhou) Co.,Ltd 18 Shexing Road, FOHO Economic Development Zone, Wujiang City, Jiangsu , China 215214		

The nameplate of the brake is on the brake.

 	
Pro. Model: WB4600B	Rated Voltage [ V ]: 110V DC
Rated Current [ A ]: 1.22A	Brake Torque: 950Nm
Air Gap: 0.3-0.4 mm	Insulation Class: F
Duty Cycle: S3-60%	Degree Of Protection: IP43
Manufacture Date:	Serial Nr.:

## 4. Technical data

Duty type:	S3 - 40%
Sheave :	Ø400mm/ Ø 450mm
Traction sheave hardness:	220-285HB
DE Bearing:	Self-aligning roller bearing
NDE Bearing:	Ball bearing
Permissible shaft load:	Max. 35,000N
Drive motor:	PM synchronous motor
Number of pole pairs:	16
Thermal class:	155°(F)
Degree of protection:	IP40
Overload capability:	2.0-fold (Imax/IN) 2 times
Winding protection:	Triple PTC 150°C

### Site conditions

Max. Attitude:	Up to 1,000 m (At high altitude decrease this value)
Ambient temperature:	-5°C... +40°C
Max. rel. humidity:	85% (No condensation at 20°C)

### Block brake

Type:	WB4600B
Max. braking torque:	≥2x950 Nm
Default setting:	≥2x1.25 M <sub>N</sub>
Air gap:	0.3~0.4mm
Nominal current:	2x1.22A
Pull in voltage/ Holding voltage:	110V DC

\* Remark: 75-80V DC for holding voltage is preferred for best performances in temperature rise

\* M<sub>N</sub> is the rated output torque of the motor

Motor Type		Synchronous 32-pole																													
		WSG-09																													
Rated Torque S3-40%, 240st/h	M <sub>N</sub> (N.m)	420				535				670				740				600				740									
Sheave	ØDt (mm)	400				400				400				400				450				450									
Loads	Q (kg)	630				800				1000/1050				1150				800				1000/1050									
Shaft load	kN	35				35				35				35				35				35									
Suspension		2:1																													
Sheave rope groove		5xØ10-18/6xØ10-15/5xØ10-15/5xØ10-16/4xØ10-12; γ=25°/30°/35°;β=90°/95°/96°														5xØ10-18/6xØ10-15/5xØ10-15/5xØ10-16; γ=25°/30°/35°;β=90°/95°/96°															
Motor current applicable to DC 500-600V	V (m/s)	ΠN [rpm]	P <sub>N</sub> [KW]	I <sub>N</sub> [A]	U <sub>N</sub> [V]	F <sub>N</sub> [Hz]	ΠN [rpm]	P <sub>N</sub> [KW]	I <sub>N</sub> [A]	U <sub>N</sub> [V]	F <sub>N</sub> [Hz]	ΠN [rpm]	P <sub>N</sub> [KW]	I <sub>N</sub> [A]	U <sub>N</sub> [V]	F <sub>N</sub> [Hz]	ΠN [rpm]	P <sub>N</sub> [KW]	I <sub>N</sub> [A]	U <sub>N</sub> [V]	F <sub>N</sub> [Hz]	ΠN [rpm]	P <sub>N</sub> [KW]	I <sub>N</sub> [A]	U <sub>N</sub> [V]	F <sub>N</sub> [Hz]	ΠN [rpm]	P <sub>N</sub> [KW]	I <sub>N</sub> [A]	U <sub>N</sub> [V]	F <sub>N</sub> [Hz]
	1.0	95	4.2	11.2	380	25.3	95	5.3	14.2	380	25.3	95	6.7	17	380	25.3	95	7.5	17.6	380	25.3	85	5.4	12.5	380	22.7	85	6.7	16	380	22.7
	1.5	143	6.3	15	380	38.1	143	8.0	19	380	38.1	143	10	23.6	380	38.1	143	11.2	25	380	38.1	127	8	18	380	33.9	127	10	22	380	33.9
	1.6	153	6.7	15.4	380	40.8	153	8.6	19.6	380	40.8	153	10.7	25.3	380	40.8	153	12	27	380	40.8	136	8.6	19	380	36.3	136	10.7	23.3	380	36.3
	1.75	167	7.4	16.9	380	44.5	167	9.4	21.4	380	44.5	167	11.7	27	380	44.5	167	13.2	28	380	44.5	149	9.4	20	380	39.7	149	11.7	25	380	39.7
	2.0	191	8.4	18.9	380	50.9	191	10.7	24	380	50.9	191	13.4	30.5	380	50.9	191	15	32	380	50.9	170	10.7	23	380	45.3	170	13.4	28	380	45.3
2.5	-	-	-	-	-	240	13.4	30.5	380	64.0	240	16.7	34	380	64.0	240	18.6	39	380	64.0	212	13.4	28	380	56.5	212	16.7	35	380	56.5	

## 5. Dimension drawing

630-1150KG(Dt=Ø400mm)

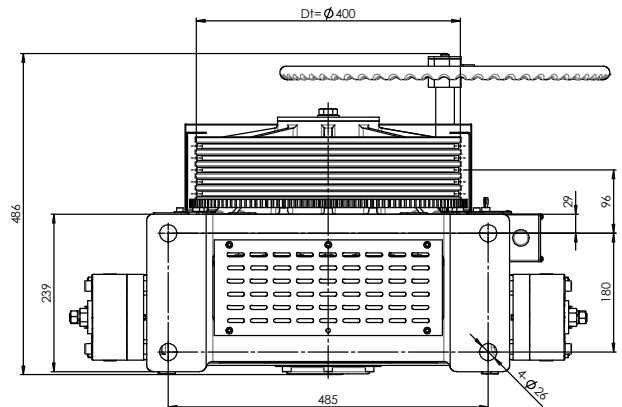
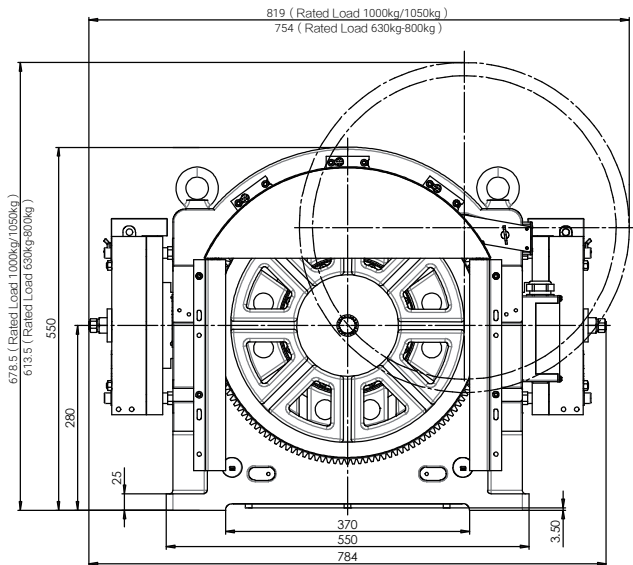

800-1050KG(Dt=Ø450mm)

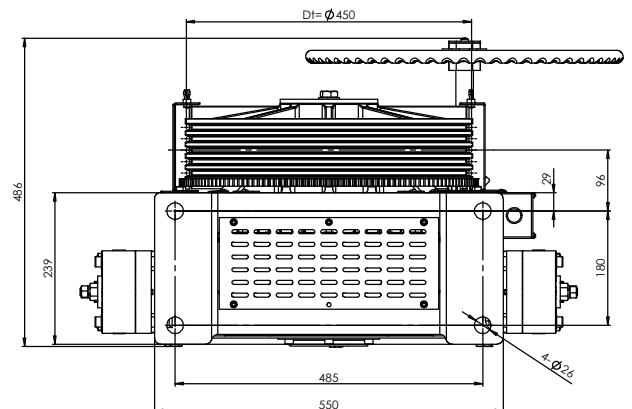
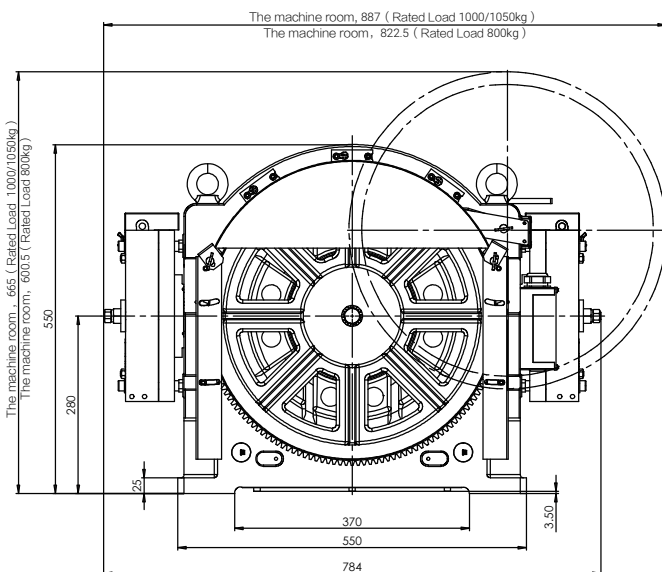



## 6. Scope of supply

- Lift machine WSG-09 according to order specification
- Operating instructions (electronic version)
- Delivery note
- Qualification certificate

### Options:

- Mechanical evacuation
- Brake remote release system (for MRL solution)
- Encoder cables
- Rope guard
- Manual release wrench (for machine room solution)

## 7. Transport and storage

The WSG-09 lift machines leave the factory in perfect condition after being tested.

Make a visual check for any external damage immediately upon their arrival on site. If any damage incurred in transit is found, make a notice of claim in the presence of the carrier. If necessary, do not put these machines into operation.

This can be done, for instance, with heated air, in a drying oven, or by applying a d.c. voltage to the motor connections.

Make sure that the voltage selected does not exceed the values shown in the figure "Drying the winding". Let the temperature rise to about 70 – 80°C and maintain it for several hours.

### Transport



Warning

Observe the relevant safety regulations and take the centre of gravity into account when handling the lift machines.

The motor must be hoisted through two eye bolts, and the load angle between the ropes shall always not be greater than 45°. The two eyebolts are designed for the specified machine weight: it is not permitted to suspend additional loads.

### Storage

Store the motors only in closed, dry, dust-free, well-ventilated and vibration-free rooms (storage temperature: -20°C to 60°C). Do not store lift machines in the open air. Parts are not sufficiently preserved to withstand extended periods of exposure.

Avoid excessive storage periods (recommendation: max. one year).

After prolonged storage (>3 months), rotate the motor in both directions at a low speed (<20rpm) to allow the grease to distribute evenly in the bearings.

Measure the insulation resistance before initial operation of the machine. If the value has dropped below < 1 KΩ per volt of rated voltage, the winding needs to be dried (insulation meter voltage: 1,000 V DC).

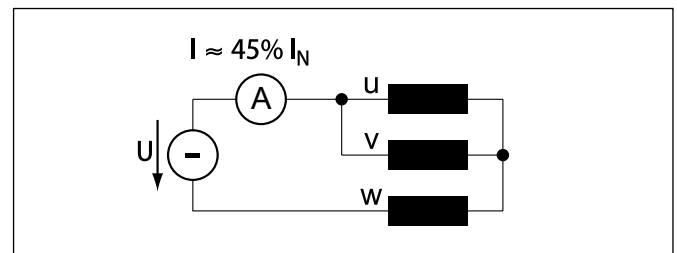

Drying the winding

### Unpacking



Note

Dispose of the packaging materials or recycle them in an environmentally friendly manner.

## 8. Installation



Caution

Be sure to check the base frame or foundation loads by calculation before installing the lift machine.

The lift machine may only be installed if the relevant safety precautions have been met. The machines can be used in lift systems with or without a machine room but only installed in vertical load case. The machines may only be installed, electrically connected and put into operation by trained specialist personnel. The system-specific conditions and the requirements of the system manufacturer or plant constructor must be met.



Warning

Cover the machine and especially the brakes when doing any machining or dust-producing work in the shaft or machine room.



Note

The measuring feedback system is only accessible from the rear side. Therefore, leave enough space (min.800mm) between the wall and the encoder side or ensure that the machine can be moved away from the wall.

### Degree of protection

WSG-09 Lift machines are designed with degree of protection IP 40. Make sure that the cable entries to the terminal boxes are sealed properly when making the electrical installation.

### Ambient conditions

The following ambient conditions must be ensured on site:

Altitude: max. 1,000 m a.s.l.

Ambient temperature: - 5 ... +40°C

Max. rel. humidity : 85 % (no moisture condensation at 20°C)

Install the machine so that ventilation is not obstructed, i.e. sufficient heat dissipation by convection and radiation must be ensured. The torque and power values indicated in the technical data are applicable to the above ambient temperatures and altitudes. In case of a deviating altitude and/or ambient temperature, the reduction factors  $k$  shown in the diagram below must be used.

$$M_{\text{permiss}} = k \cdot M_N \quad P_{\text{permiss}} = k \cdot P_N$$

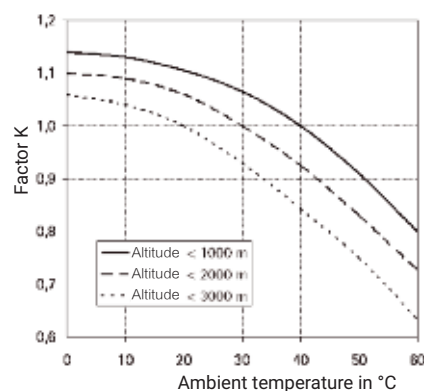

### Fastening the machine



Note

The machine or base frame should be mounted on rubber pads for vibration damping.

The machine is fastened using 4×M24 bolts (strength class 8.8);

The permissible unevenness of the mounting surface is 0.1 mm.

The mounting surface must be sufficiently distortion-resistant and stable to accommodate the forces occurring in the system.



Danger

After completing the adjusting work, tighten the 4 × M24 bolts of the machine.



Warning

No welding work may be performed on the lift machine. This could destroy the bearings and the magnets.

Assembly rope slip-off guards:

For traction machine with traction sheave diameter is 400 mm, the rope must be put in right place after the adjustment, so that the distance between the rope and rope slip-off guards is not more than 1-2 mm; For traction machine with tractive sheave diameter is 450 mm, rope slip-off guards together with protection cover, and not adjustable.

## 9. Electrical connection

### 9.1 General



Danger

The electrical connection may only be made by a qualified electrician. Before starting any work on the machines, ensure that the lift machine or system is properly isolated.

Before making any connections check that

- the connecting cables are suitable for their specific application and for the relevant voltages and currents
- sufficient dimensions of connection wires are provided and necessary protection is given.
- make sure the ground wire is connected to the grounding terminal or the grounding bolt.
- there are no foreign bodies, dirt or moisture in the terminal boxes.
- cable entries not in use and the terminal box itself are tightly sealed to prevent the ingress of dust or water.



Note

The insulation system of the motors is designed such that they can be connected to a converter with the maximum bus voltage of 620V DC.

Note: bus voltage can only be instantaneous and approximately equal to the initial voltage of the brake chopper or energy recovery device.

### 9.2 Motor connection / Winding protection

The electrical connection of the motor and the winding monitoring devices is made in the terminal box on top of the machine. There's connection advice stick inside the box as following.

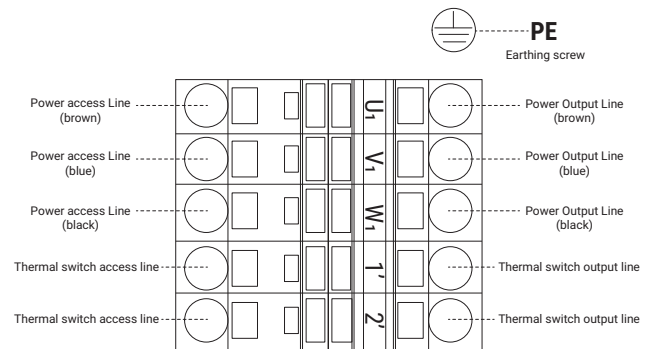

Caution

The cable must be insulated and protected. The motor phase U1, V1 and W1 must be connected to the frequency converter and not interchangeable. The PTC thermistor must be correctly connected to the control system.

#### PTC- Thermistor



Caution

The thermistor connected to the stator iron must be monitored by the elevator control system to prevent excessive temperature of the motor.

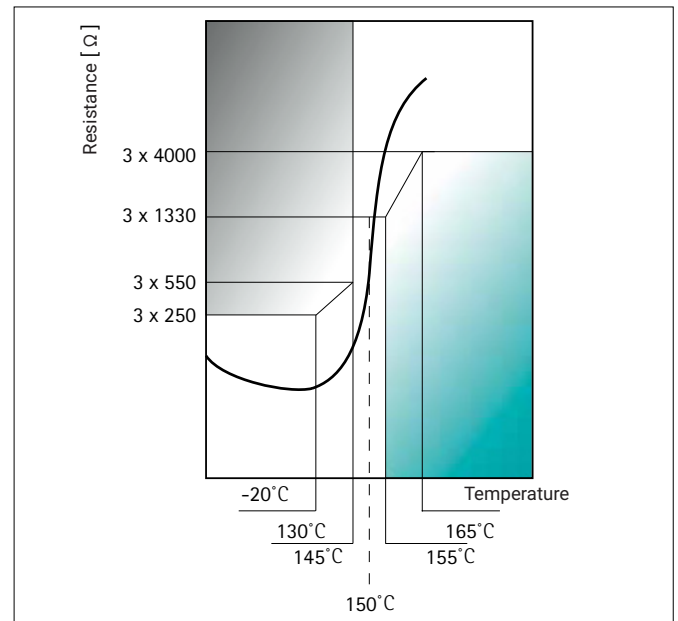

Subject to change without notice!

**Cable cross-section required (recommended):**

Traction sheave Dia.	Rated load	Rated speed	Cross-section
400mm	630kg	1-2m/s	4mm <sup>2</sup>
	800kg		
	1000/1050kg		
	800kg	2.5m/s	6mm <sup>2</sup>
	1000/1050kg	2.5m/s	
1150kg	1-2.5m/s		
450mm	800kg	1-1.75m/s	4mm <sup>2</sup>
	800kg	2-2.5m/s	6mm <sup>2</sup>
	1000/1050kg	1-2.5m/s	

The WAGO terminal strips are suitable for the following types of copper conductors:

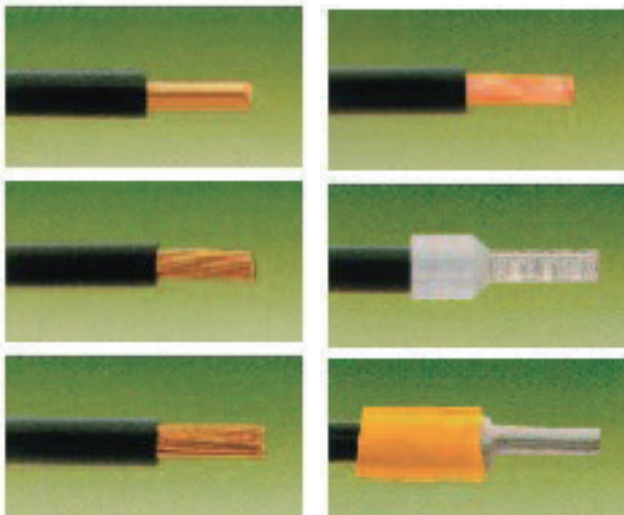

(When using the nominal cross-sections with ferrules, the usable cable cross-section is reduced, 9-10mm copper wire must be exposed for wiring)

The currents specified under the machine data for the series WSG-09 refer to duty type S3-40%. This must be taken into account when selecting the cable cross section required. The continuous I<sub>r.m.s.</sub> value required for the selected cable is approximated from:

$$I_{r.m.s.} \text{ (cable)} = I_n \text{ (motor, S3-40\%)} / 1.58$$

The following table gives the recommended values for the current carrying capacity of PVC cables at a maximum ambient temperature of 40 °C:

CABLE CROSS SECTION	PERMISSIBLE MAX. CURRENT (R.M.S. VALUE)	PERMISSIBLE MAX. MOTOR CURRENT I <sub>n</sub> (S3 - 40%)
1.0 mm <sup>2</sup>	13.1 A	20.7 A
1.5 mm <sup>2</sup>	15.7 A	24.8 A
2.5 mm <sup>2</sup>	22.6 A	35.7 A
4.0 mm <sup>2</sup>	29.6 A	46.7 A
6.0 mm <sup>2</sup>	38.3 A	60.5 A

**Wiring**

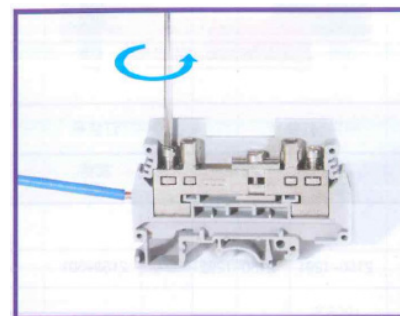

Assembly and disassembly of conductor

**Earthing**

For safety reasons, it is very important to use the earthing bolt M6 in the terminal box to ground the motor correctly.



Warning

An earthing screw is provided on the motor frame for the connection of a protective or earthing conductor as specified in VDE 0100 and VDE 0141 respectively.

**Short-circuiting**



Note

The motor terminals of the synchronous lift machines, type WSG-09, can be short circuited, if required, to brake the lift machine faster. This is, however, only permissible at speeds less than the rated speed of the respective motor.

### 9.3 Speed/Position measuring feedback system

Lift machine of WSG-09 are equipped with ECN1313 EnDat or ERN1387 encoder from Heidenhain or encoder of TS5213N2503 from TAMAGAWA and EI53C9.25-2048- SA5N2T from Weton.

1. Heidenhain ECN1313 EnDat is an absolute encoder which is connected by a signal plug connector at the housing of it.
2. Heidenhain ERN 1387 is a sine-cosine incremental encoder. It is connected via a signal plug connector, which is also connected to the encoder's housing.
3. TAMGAWA TS5213N2503 is a sine-cosine incremental encoder. The encoder is connected by a signal DB plug, and the connector is drawn from the end of the encoder.
4. Weton EI53C9.25-2048-SA5N2T is a sine-cosine incremental encoder. The encoder is also connected by a model plug, and the connector cable is at the end of the encoder.



Note

We recommend the use of an appropriate cable set to connect the measuring system to the converter system. Cable sets can be supplied as accessories.



Warning

The measuring system of the WSG-09 lift machines is matched to the associated converter. Do not make any adjustments or changes, otherwise the motor may not work.



#### 9.3.1 Measuring feedback system ERN 1313

Resolution: 2048

Operating voltage: 5V

Data interface: EnDat

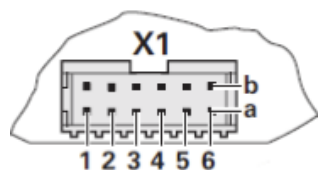

X1

1b	6a	4b	3a	2a	5b
Up	Sensor Up	0V	Sensor 0V	A+	A-

4a	3b	6b	1a	2b	5a
B+	B-	DATA	DATA	CLOCK	CLOCK

#### 9.3.2 Measuring feedback system ERN 1387

Resolution: 2048

Operating voltage: 5V

Commutation signals: sine and cosine

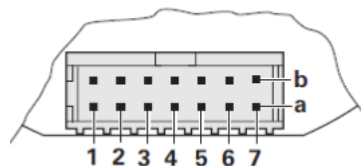

1b	7a	5b	3a	6b	2a	3b
Up	Sensor Up	0V	Sensor 0V	A+	A-	B+

5a	4b	4a	7b	1a	2b	6a
B-	R+	R-	C+	C-	D+	D-

### 9.3.3 Measuring feedback system TS5213N2503

Resolution: 2048

Operating voltage: 5V

Commutation signals: sine and cosine



Picture of DB-15PIN male terminal

1	2	3	4	5	6	7	8	9	10	11	12	13	14	15
B-		R+	R-	A+	A-	0V	B+	5V	C-	C+	D+	D-		

### 9.3.4 Measuring feedback system Weton EI53C9.25-2048-SA5N2T

Resolution: 2048

Operating voltage: 5V

Commutation signals: sine and cosine

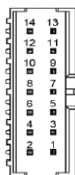

2*7 Plug	3	12	9	6	7	8	1
Function	A	A-	B	B	Z	Z-	C
2*7 Plug	14	11	4	2/13	5/10	shield	-
Function	C-	D	D-	+5V	0V	shield	-

### 9.4 Brake

The brakes must be DC powered, with a standard maintenance voltage of 110 V DC, best at 75-80 V DC. Rectifiers and related circuits shall be supplied by the customer control cabinet.

#### Notes on the use of DC/AC side switching:

AC side switching is recommended for normal operation, since the lift machine is then decelerated in a controlled manner to zero speed and the switching noise of the brake is negligible. Switch from the DC side in case of failure (emergency stop) or during inspection drive, as this ensures faster braking effect with the lift car being stopped earlier. It is therefore recommended to use 2 separate contactors for the brake control circuitry, one of which switching at the DC side, the other one at the AC side. If the brake is used as an anti-car accidental movement protection device (UCMP), only the dc side control switch can be used.

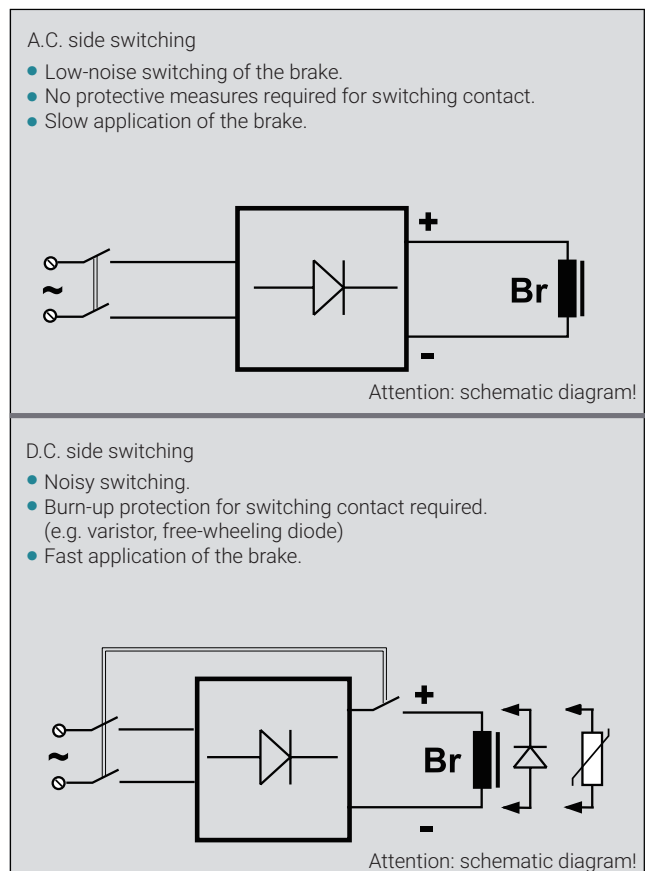

## Brakes

The switching state of the brakes is monitored using dust-proof micro switches with metal contacts. Two kinds of signals are provided, usually on and off. See the brake label for specific connection. The customer can choose the connection mode according to the control system.



**Danger**

The switches must be individually checked for each brake, ensuring each is working properly. Different connection modes provide different signals to the control system. Please choose one of the two.

## 10. Commissioning

The following points should be checked or completed:

- Remove all securing, auxiliary and installation tools from the danger area.
- Check that the lift machine is used for its intended purpose and that the permissible ambient conditions are met.
- Check that the lift machine is properly fastened.
- Are all bolts tightened with the specified torque and secured?
- Check the motor connection, especially the earthing.
- Check that the PTC-thermistor (temperature monitoring device) is properly connected and functioning.
- Check that the brakes are properly connected and that the brake monitoring switches are functioning properly.
- Is the encoder system properly connected?
- Check the proper functioning of the brake; perform a braking test using one partial brake.
- Is the rope slip-off guard properly tightened and adjusted?
- Check that the remote control of the brake release device is working, if provided.



**Note**

An initial functions test of the motor and the brake, together with the converter, should be performed before the ropes are put in place.

## 11. Operation and maintenance

### 11.1 General

The regulations concerning operation, maintenance and inspection in accordance with the applicable safety regulations in lift construction such as EN 81 "Safety rules for the construction and installation of lifts", Part 1: "Electric lifts" and other relevant regulations are to be strictly observed.

The operator is responsible for the proper installation of the motor with regard to safety requirements as well as for its inspection and maintenance as specified in the applicable regulations.



**Danger**

The proper maintenance of gearless lift machines requires adequately trained specialist personnel and specialized devices and tools.

For reasons of responsibility, maintenance work outside the scope of this instruction must not be performed by electrical machinery installation / maintenance technicians.

### Bolt/screw tightening torques



**Warning**

When doing any work on the machine or replacing parts, make sure that the specified bolt/screw strength class and the tightening torques are observed (see table). Secure the bolts/screws with "omnifit 100" or a similar product against accidental loosening.

Dimension	Tightening torque[Nm]		
	8.8	10.9	12.9
Strength class			
M 4	2.8	4.1	4.8
M 5	5.5	8.1	9.5
M 6	9.6	14	16
M 8	23	34	40
M 10	46	67	79
M 12	79	115	135
M 16	195	290	340
M 20	395	560	660
M 24	680	970	1150

### 11.2 Maintenance intervals

Check the bearing noise	every three months	
Check the brake air gap	every three months	see section 11.7
Check the proper functioning of the brakes and the brake microswitches	every three months	see section 11.7
Check the traction sheave for wear	every six months	
Check the rope slip-off guard	every six months	
Check the electrical cables	every six months	see section 9
Check the guards and safety devices for their condition and safe functioning	every six months	
Check the tightening torques of the frame, brake and traction sheave fastening bolts/screws	every six months	see section 12.1
Clean the external machine surfaces	as required	



### 11.3 Brake remote release for MRL solution

A brake remote release system would be required when it is a MRL solution. Besides the standard brake, the system additionally consists of cam mechanism, dragline subgroup and operation mechanism.



Note

Pay attention when installing

- 1 As less bending as possible for dragline to reduce the friction between dragline and spool.
- 2 Radius of curvature  $\geq 200\text{mm}$  at the area of bending.
- 3 Place the system in an area where is easy for operation. Either horizontal or vertical installation is acceptable.

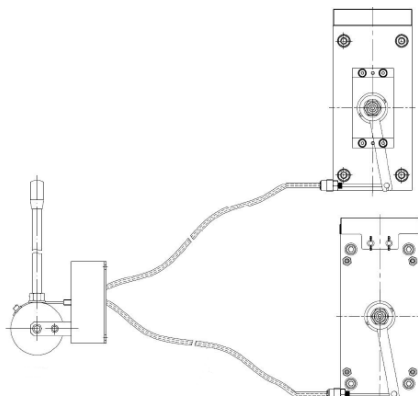
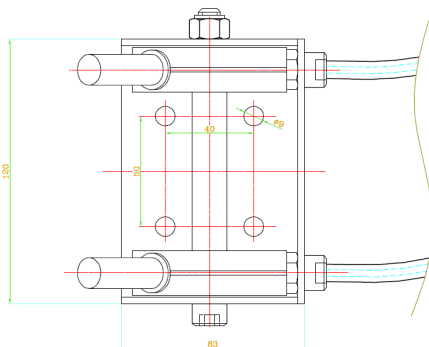

### 11.4 Mechanical evacuation device

When the mechanical evacuation device ordered, a big gear is machined on the traction sheave. In urgent case, insert the Hand wheel shaft (mounted with a small gear) into the supporting hole on housing then turn the traction sheave by engagement to move the car.

### 11.5 Replacing the traction sheave



Danger

The traction sheave has to be replaced when a limited situation.

#### Disassembly

- Power off the system and safeguard against unintentional reclosing.
- Lift the car and counterweight to ensure that the wire rope can be removed from the traction sheave.
- Remove the rope slip-off guards and the rope guards, if provided.
- Relieve the load on the traction sheave; remove the ropes.
- Support the traction sheave by means of a hoisting gear.
- Remove the end cover of the traction sheave end.
- For easy disassembly, heat traction sheave (recommended use of portable small electromagnetic heater on site).
- Use puller fixture to pull out the traction sheave by the 4 bolts of M4×10, the figure as follows:

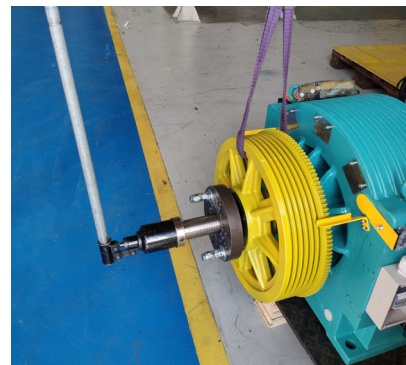

#### Assembly

- Clean the traction sheave and the shaft-end.
- For better assembly heat up traction sheave (portable electromagnetic heater is recommended on site).
- Slide the traction sheave onto the shaft and align the keyway.
- Assemble the end cap and use "omnifit 100" or a similar adhesive to secure the bolts. Tighten them along the bolt hole circle (MA = 80 Nm) with a torque spanner.
- Replace the ropes and reinstall the rope slip-off guard.

### 11.6 Brake



Note

Electromagnetic brake is a kind of mechanical and electrical product with high safety requirement. It is always pre-adjusted before delivery. It can only be assembled, adjusted and maintained by the manufacture of traction machine with qualified skills for certain purpose on the field. The responsibility will not be taken if the above instruction is not complied.

#### Operation condition

Ambient temperature: -5°C...+40°C  
 Max. rel. humidity: 85% (No condensation at 20°C)  
 IP: IP43

#### Replacement of the brake



Note

When brake lining is worn out to the thickness less than 3mm or noise of the brake is more than standard value(see the following table) during working and can't be used any more, the brake (friction pad) should be replaced.

Item	Rated torque of traction/N.m	
	≤700	>700 and ≤1500
Noise of the brake/dB(A)	≤70	≤75



Danger

Before replacement, power off the system and safeguard against un-intentional reclosing. Secure the car and the counter-weight and make sure there's no loading on the traction sheave.

#### Procedure of disassembly

- Disconnect all connections on the brake terminal.
- Relieve the 4×M10 bolts as it is showed below

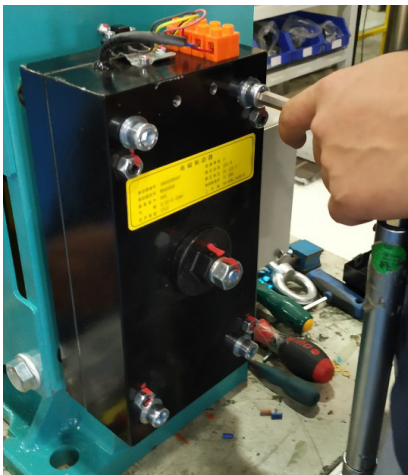

#### Procedure of assembling and adjustment

1. Screw the adjustment sets into the bottom place of the brake. (Shortest length outside)



2. Move the brake close to the fixing area on traction machine.
3. Hang up the brake on the traction machine with four M10 screws. (When tightening the installation screws, the gap between static plate and moving plate becomes smaller from originally 1.2 ~ 1.4mm).
4. Relieve the cross screws to remove the switch cover.



5. Use a feeler gauge to measure the gap (operation gap) between the static plate and moving plate. To confirm the four corners of the brake have a uniform air gap at 0.3mm-0.4mm. Moreover, to confirm the four installation screws have the same force (see below).

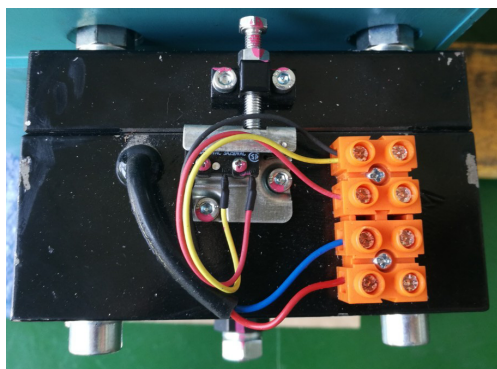

6. Screw out the adjustment sets to touch the surface of the housing. Use torque spanner to tighten the installation bolts (M10-10.9) with reserved force to make sure these screws and the adjustment sets could lock each other closely. Locking torque should be no less than 67Nm to avoid loosen.



7. Finish the wiring as following

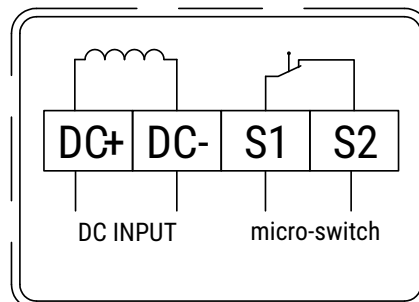

8. After setting, power on the brake. The moving plate would be pulled in. Use the feeler gauge again to measure the gap between the brake lining and the brake wheels to check whether the gap is 0.10mm ~ 0.20mm (with the contact area above 75%). If not, continue to fine tuning the installation screws and adjustment sets. At the same time, confirm that during interruption of power supply, the air gap between static plate and moving plate should still keep uniform at 0.3 ~ 0.4mm.

### Adjustment of microswitch

1. the brake is installed on the test fixture or traction machine, and the brake air gap is within the specified range(0.3~0.4mm).
2. Insert a 0.15mm feeler gauge into the brake gap, and power on the brake. Use the multimeter to detect whether the micro switch is activated, turn the adjustment screw to make the micro switch exactly activated, and tighten the nut to eliminate the impact of thread clearance. Power off the brake, Insert a 0.2mm feeler gauge into the gap, and then power on the brake again, micro switch should not be activated. Alternately insert 0.15mm and 0.2mm feeler gauge into the brake gap, repeatedly power on/off the brake, detect the micro switch action state, by adjusting screw to make micro switch activated at 0.15 mm gap but not activated at 0.2mm, that is, micro switch activating point is at a gap of 0.15~0.2mm.

Detection: use 0.1mm and 0.25mm feeler gauges respectively to detect in accordance with above method, and the micro switch should be activated or not correspondingly.

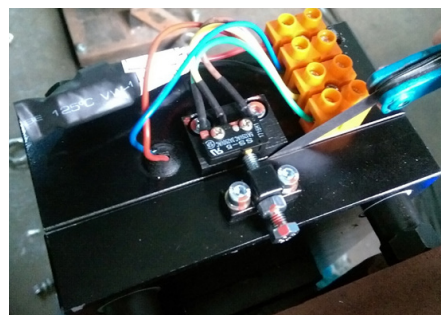

### Precautions for the use of brakes

- Ensure working situation of brake is inside the min. ambient condition.
- Ensure the electromagnetic brake works under the designed duty.
- Prevent brakes from dropping or colliding during transportation and disassembling. Avoid damaging the mechanical parts or electrical components.
- When use the hand release to manually open the brake, avoid excessive force which may results in brake damage, and avoid barbaric operation;
- After a long term period running of the traction machine, the braking lining may be abraded. The brake gap would be increased to cause a loudly noise. In case the thickness of brake lining is less than 3mm or the noise of the brake higher than standard requirement, the brake must be re-adjusted or replaced by specialized technician.



Note

Brake lining thickness  $b=5\text{mm}$ , it should be replaced when worn out to the thickness less than 3mm.

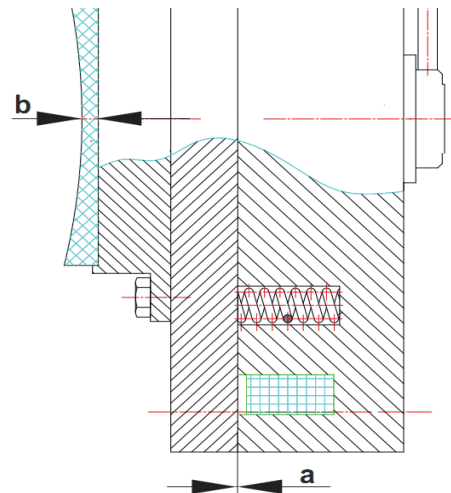

Note: when value  $a$  is greater than 0.6, we need to re-adjust the gap between moving and static plates according to Step 5-8 on page 18.

### Maintenance

- The block brake requires a high quality of installation because of the special construction characters. It is common that in the beginning after the machine and brake handover to customer, the gap may increase a little bit because the brake lining cannot match to brake wheel in 100%. It requires attention frequently. When the air gap turns larger (noise level would increase at the same time), the adjustment is required immediately. When adjusting, the four adjusting sleeves should be evenly screwed in the same displacement to ensure that the brake lining moves inward. In addition to regular monitoring of air gap, other aspects may not be maintained.
- The duty cycle of block brakes is S5-60%, the brakes could not work in normal in certain special condition which gives a high temperature such as: long working period with high electricity more than 60%, or environmental temperature goes up to more than 40°C. These will all lead to failure alarm of traction machine. In such cases, the maintenance company should communicate with the user in time, standardize the use frequency of elevator, and improve the working environment of machine room.
- The operation voltage to be checked regularly otherwise it may cause brake damage by high voltage or operation failure by low voltage.
- After a long time running, the gap may become big by the abrasion of the brake lining. In this case, the noise of the braking will be louder and the responding of the braking will be longer with a safety risk. Therefore, a report to the maintainer for maintenance is constraint.

## 11.7 Removing encoder system



Note

The measuring system is only accessible from the rear side of the motor.



Warning

Disassemble the measuring system only if this is necessary because of a defect. Remember to readjust the offset value after reassembly (see the converter operating instructions).

### Heidenhain encoder: ECN 1313 EnDat and ERN1387, Weton encoder: EI53C9.25-2048-SA5N2T Assembly

- Remove the cable cover.
- Fix the encoder to the fixing seat.
- Insert the M5×50 fastening screw in the hollow shaft and tighten the screw.
- Tighten the clamping ring on the measuring system.
- Insert the cable p.c.b. connector (observing the designation "TOP" or the guiding nose).
- Fasten the encoder cables.
- Reinstall the cable cover.

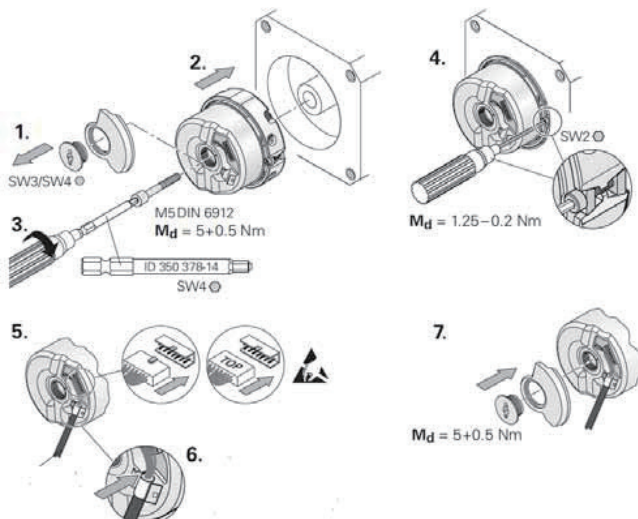

## Disassembly

- Remove the cable cover from the measuring system; pull out the cable p.c.b. connector.
- Loosen the clamping ring on the measuring system (2mm Allen screw).

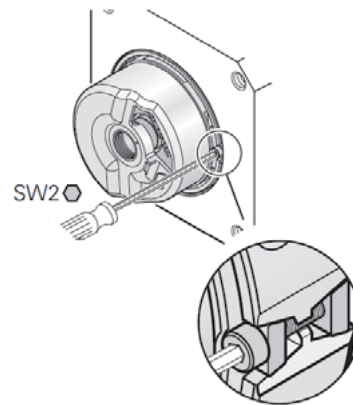

- Remove the M5 fastening screw
- Insert the M5×10 setscrew to protect the thread (see figure) and remove the measuring system by means of the M6×70 forcing screw.

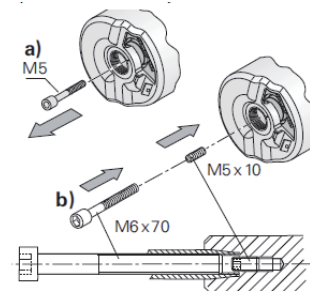

Note

It is required to use different cables for encoders. Please take attention when reinstalling.

### TAMAGAWA encoder: TS5213N2503 Assembly

- Fix the encoder to the fixing seat.

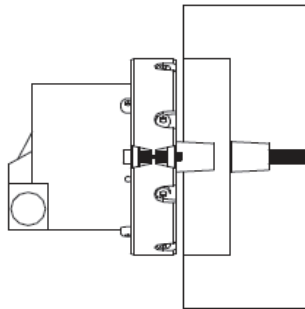

- Insert the M5×45 fastening screw in the hollow shaft and tighten the screw.

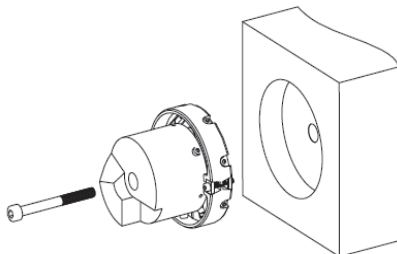

- Tighten the clamping ring on the measuring system.

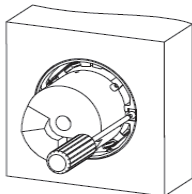

### Disassembly

- Loosen the clamping ring on the measuring system (2mm Allen screw).

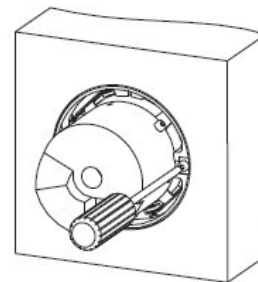

- Remove the M5 fastening screw.

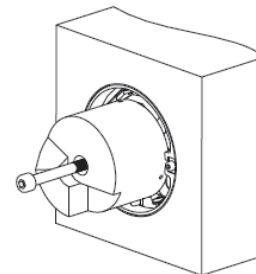

- Insert the M5×10 setscrew to protect the thread (see figure) and remove the measuring system by means of the M6×60 forcing screw.

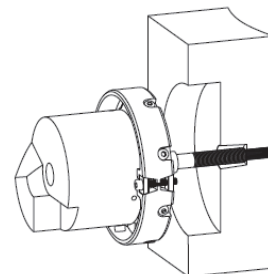

Note



It is required to use different cables for encoders. Please take attention when reinstalling.

## 11.8 Trouble shooting

Fault	Possible cause	Remedy
Motor does not start, operates out of control or develops no torque	<ul style="list-style-type: none"> <li>• Motor not connected in proper phase sequence</li> <li>• Measuring feedback system not properly connected</li> <li>• Converter parameterization incorrect</li> <li>• EMC disturbance</li> <li>• Measuring system offset angle incorrectly set</li> </ul>	<ul style="list-style-type: none"> <li>• Connect motor correctly</li> <li>• Connect measuring feedback system (encoder) correctly</li> <li>• Check converter parametrisation</li> <li>• Carry out shielding and earthing measures as described by the converter manufacturer</li> <li>• Check measuring system offset angle</li> </ul>
Motor noise	<ul style="list-style-type: none"> <li>• Bearing defective</li> <li>• Converter parametrisation incorrect</li> </ul>	<ul style="list-style-type: none"> <li>• Notify customer service</li> <li>• Check converter parametrisation</li> </ul>
Braking system does not release	<ul style="list-style-type: none"> <li>• Braking system is not supplied with voltage</li> <li>• Brake power supply voltage is too low</li> </ul>	<ul style="list-style-type: none"> <li>• Check electrical connection</li> <li>• Check braking voltage supply voltage</li> </ul>
Brake switch noise	<ul style="list-style-type: none"> <li>• Brake mechanically blocked</li> <li>• Control cabinet rectifier fault</li> </ul>	<ul style="list-style-type: none"> <li>• Remove mechanical blocking</li> <li>• Replace the rectifier</li> </ul>
Delay in braking system release	<ul style="list-style-type: none"> <li>• Control cabinet rectifier fault</li> </ul>	<ul style="list-style-type: none"> <li>• Replace the rectifier</li> </ul>
Braking system does not engage	<ul style="list-style-type: none"> <li>• Brake shoe mechanically blocked</li> </ul>	<ul style="list-style-type: none"> <li>• Remove mechanical blocking</li> </ul>
Delay in engaging of braking system	<ul style="list-style-type: none"> <li>• Brake defective</li> </ul>	<ul style="list-style-type: none"> <li>• Remove mechanical blocking</li> </ul>
Brake makes loud switching noise	<ul style="list-style-type: none"> <li>• Brake air gap too large</li> </ul>	<ul style="list-style-type: none"> <li>• Adjust brake air gap</li> </ul>
Braking torque too low	<ul style="list-style-type: none"> <li>• Brake friction surface or brake linings dirty.</li> <li>• Foreign bodies between friction surface and brake lining</li> <li>• Brake friction surface or brake lining have come into contact with oily or greasy materials</li> <li>• Load torque too high</li> </ul>	<ul style="list-style-type: none"> <li>• Clean friction surface / brake linings</li> <li>• Remove foreign bodies</li> <li>• Replace brake lining, clean brake drum thoroughly</li> <li>• Reduce load torque</li> </ul>

## 12. Accessories

### 12.1 Connecting cable for encoder systems

Converter	Connection	Encoder	Order number
Emerson Unidrive Yaskawa-L1000		ECN1313 EnDat	Z320WSGS30010V0X
Schneider		ERN1387/ Ei53C9.25-2048-SA5N2T	Z320WSGS30006V0X
Monarch Meiden VT Xizitrust Micovert			Z320WSGS30008V0X
Fuji		ECN1313 EnDat	Z320WSGS30009V0X
iAstar			Z320WSGS30030V0X
iAstar		ERN1387/ Ei53C9.25-2048-SA5N2T	Z320WSGS30032V0X
SIEI			Z320WSGS30026V0X
KEB Emerson Soder			Z320WSGS30007V0X
Monarch			Z320WSGS30031V0X

Others: V01=7m, V02=10m

Converter	Connection	Encoder	Order number
Schneider		TS5213N2503	Z320WSGS30073V0X
Monarch Meiden VT Xizitrust Micovert			Z320WSGS30074V0X
iAstar	Z320WSGS30079V0X		
SIEI	Z320WSGS30078V0X		
KEB Emerson Soder	Z320WSGS30075V0X		
Monarch	Z320WSGS30076V0X		

Others: V02=7m , V03=10m



## 12.2 Hand wheel of mechanical evacuation device

In urgent situation, like power off or emergency rescue, in case the system weight at car side equals to cwt side, the car can not move naturally, then the hand wheel can be inserted into the connecting seat. By turning the wheel, the lift car can be moved to the near floor and to be rescued.



## 12.4 Manual brake release wrench

When used in a machine room, professionals can release the brake for rescue work by using a manual brake release wrench.







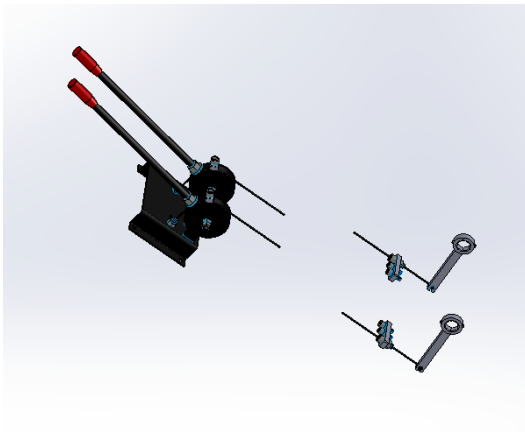

## 12.3 Brake remote release

When the lift machine is installed in the MRL shaft, the professional can release the brake through the remote release device to carry out rescue work.



### 13. Spare parts

Spare parts	Picture
Brake	 x2
Remote release accessories	
Manual release wrench	
Traction sheave	
Encoder ERN 1387	
Encoder ECN 1313 EnDat	
Encoder TS5213N2503	
Encoder EI53C9.25-2048-SA5N2T	
Encoder cables	See accessories in sections.



WITTUR

**YOUR GLOBAL PARTNER FOR COMPONENTS,  
MODULES AND SYSTEMS IN THE ELEVATOR INDUSTRY**

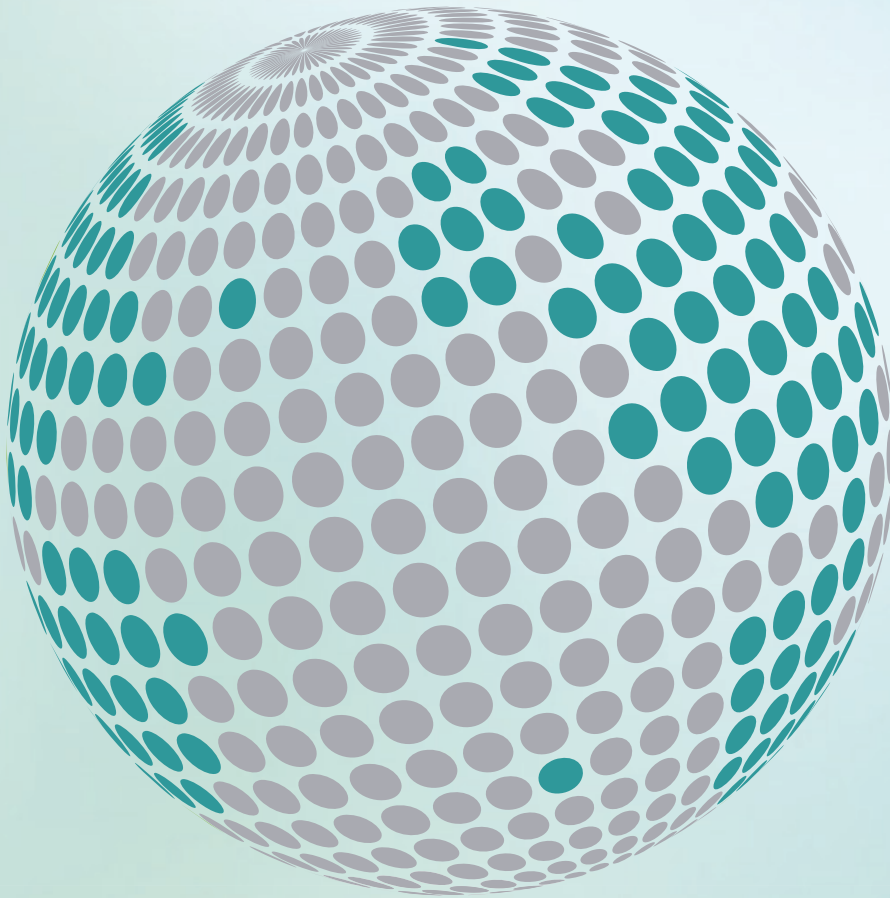

*safety* **in** *motion*™

[www.wittur.com](http://www.wittur.com)

More information  
about Wittur Group  
available on-line.



**SELCOM**®  
a WITTUR brand

**Liftmaterial**  
a WITTUR brand

**sematic**®  
a WITTUR brand